

# GL-D31 User Manual

Thank you for using our company's products, before using this product, please read the user manual carefully. When you start to use this equipment, we believe that you have read the user manual carefully.



**Attention:** Secure Startup: avoid turning on the equipment in the very dry or humid environment, to prevent damaging of the equipment;



Using qualified maintenance services: only qualified maintenance personnel can repair the equipment, Please do not dismantle the equipment by yourself.



Connected to other devices: when connected to other equipments, please read the user manual of the equipment to obtain detailed safety instructions, do not connect to the device that is not equipped with the device.



**Back Up:** Important data of this equipment please do a back up, any error operational methods resulting in paper loss , the Company shall not be responsible for.

- ① Video Recording/Stop
- ② Turn ON/OFF/Photo
- ③ LED ON/OFF
- ④ Reset
- ⑤ TF card Slot
- ⑥ Mini USB
- ⑦ Camera
- ⑧ LED Light

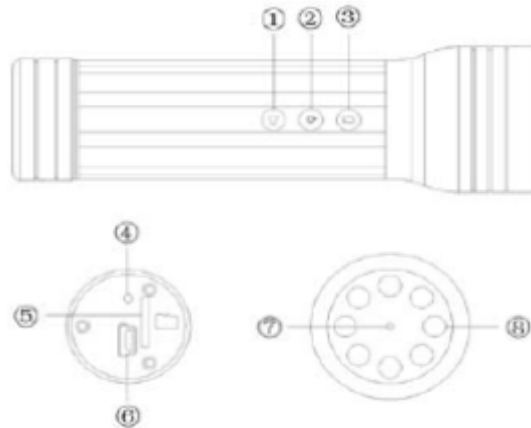

## Operation Instruction

**Power on:** Press the ② button for two seconds, the red light is on, it indicates the device is turned on and has entered standby mode.

**Note:** The following operations are required to operate in standby mode and ensure that the identified T-Flash card was inserted to the card slot properly.

**Video REC:** In standby mode, press shortly ① button once, the green light is on, now it is in the mode of video recording , and the light is green all the time when recording. In the video recording mode, press shortly ① button once , two seconds later ,the green light will turn to red, video files will be saved automatically, at this time ,red light is on, the equipment automatically returns to standby mode, if you want to record again, just repeat the above operation.

**Photograph:** In standby mode, press shortly ② button once, then the green light will twinkle once, it indicates the device has finished taking photos and automatically return to the standby mode, If you want to photograph again, just repeat the above operation.

**Power off:** In any mode, press the ② key for two seconds, all lights will turn off, it indicates the equipment has been shut off.

**Lighting:** press shortly ③ key once, LED light is on, press shortly ③ key once again , LED light is off.

**Time watermarks:** video files with time watermarks. it can be modified, we did not adjust the time of equipments when it came from factory, if you found it is not accurate , it's easy to adjust by yourself, just use the USB cable and connect the equipment to the computer, at the same time, run the CD-ROM, copy the file "Time.txt" into root directory of USB Flash Disk, then pull out device from computer, and the file "Time.txt" will be also deleted by itself, then restart and power off once. The modification of time is finished.

## PC Camera:

Press the ② key and insert the computer USB, then you can enter the PC Camera Mode.

Charging: In the course of using, if red light twinkling constantly, that means the electric volume of the host is low, the machine with the standard USB2.0 interface, can use computer USB port to recharge, can also use DC5V charger to recharge; if the red light is twinkling, it means it is charging. When red light stops twinkling and then keeps on, it means the recharging finished. please pull out the machine from computer in time, to prevent batteries being damaged.

## FAQ:

Q: Why it does not have any response after pressing the ① and ② button continuously.

A: Because all operation needs going back to the standby mode, then we can do the next step. The particular operation is written in the manual.

Q: Why the time watermark is not accurate enough after updating the system time?

A: Because the battery support the working of system time. Please do not exhaust the battery and charge the battery in time, or keep the battery full and adjust the time before you use it.

Q: Why I can not find the mobile hard disk after the equipment is connected to the computer?

A: Please confirm your computer's operating system. It can identify and install the correspond drivers automatically in WINDOWS98/SE/ME/2000/XP/MAC OS/LINUX. WINDOWS98 system need to install drivers which is recorded in the CD-ROM.

Q: Why the picture is not so clear?

A: The equipment does not possess the function of preventing free of shaking, Please keep your hands and the object do not shake.

### **GREENLEAF ENTERPRISE CO.,LTD.**

Address: No 388, Chung-Hsi ao E.Rd, Sec. 6, Taipei, Taiwan

TEL: 886-2-2788-8787 FAX: 886-2-2788-9988

Website: <http://www.greenleaf.com.tw> <http://www.taiwan-spy.com>

E-Mail: [service@taiwan-spy.com](mailto:service@taiwan-spy.com)